

m2k-TA-1060-1000

Tapered Amplifier for MOPA Setups

m2k **L**aser

High-Brightness Diode-Lasers

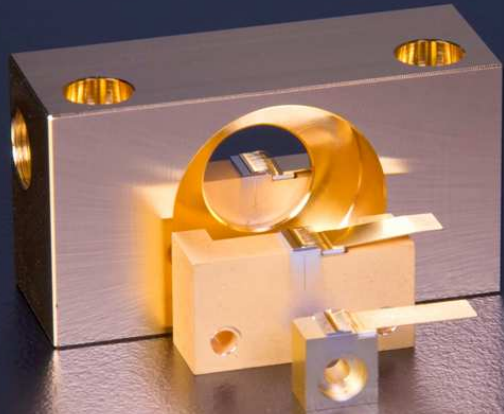

Operation range: 1040 – 1064 nm
Output power: 1000 mW
 M^2 : < 1.5
Side mode suppression: > 40 dB
AR coating: < 0.01%
Packaging: C-mount / DHP-I / DHP-F

General Description

GaAs based tapered amplifiers are used for the amplification of an existing seed laser. The seed power between 10 mW and 30 mW can be amplified up to nearly diffraction limited power values of 1000 mW. Such a setup is called MOPA (Master Oscillator Power Amplifier). The rear facet and the front facet are both provided with an anti-reflection coating of less than 0.01% to avoid laser action of the amplifier chip itself. Application examples for MOPA setups with tapered amplifiers are optical cooling, optical traps or high resolution absorption or Raman spectroscopy.

Advantages

- tuning range between 1040nm and 1064nm
- suitable for MOPA setups up to 1000 mW
- nearly diffraction limited with M^2 ($1/e^2$) < 1.5
- side mode suppression of more than 40 dB
- highly anti-reflection facet coatings < 0.01%
- passive cooling
- different packages available

C-Mount



DHP-I

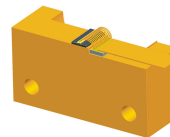

DHP-F

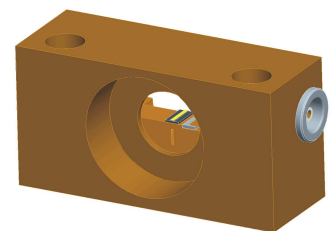

Options

- The m2k-TA-1060-1000 can be mounted on a c-mount or optionally on a DHP inset or a DHP frame for better handling.
- The m2k-TA-1060-1000 can be ordered with selected beam quality parameters M^2 .
- The m2k-TA-1060-1000 is also available for external cavity configurations, see product data sheet m2k-TAL-1060-1000.



m2k-laser GmbH
Hermann Mitsch Str. 36a
D-79108 Freiburg

Fon: +49 (0) 761 5158-7370
Fax: +49 (0) 761 5158-7376

Email: info@m2k-laser.de
Internet: www.m2k-laser.de

m2k-TA-1060-1000

Specification Data

m2k *Laser*

High-Brightness Diode-Lasers

Product		m2k-TA-1060-1000
Spectral data		
Wavelength operation range	nm	1040 - 1064
ASE suppression	dB	> 40
Typical seed power ¹	mW	15
Maximum seed power ¹	mW	30
Minimum seed power ¹	mW	10
Beam parameter output facet		
Output aperture at front side	µm	215x1.3
Divergence parallel (95%)	°	6
Divergence perpendicular (95%)	°	65
M ² ²		< 1.7
Astigmatism	µm	depends on operating conditions
Electrical data		
Typical operation current (500mW)	A	2.9
Typical operation current (1000mW)	A	2.1
Maximum operation current with injection	A	3
Maximum operation current without injection	A	2
Operation voltage	V	< 1.6
Polarization		TE
Thermal data		
Operating temperature	°C	15 ... 30
Recommended heat sink temperature	°C	20
Storage temperature ³	°C	-20 ... 60
Operating conditions		non-condensing atmosphere
Package		
Heat sink type		c-mount
Cavity length	µm	2000
Cathode (-)		wire flag
Anode (+)		base plate
Other specifications		
RoHS 2002/95EC compliant		yes
Optional		
Packaging		
Heat sink type		DHP-inset (DHP-I), DHP-frame (DHP-F)
Connector		customized connector cables
Related Products		
For External Cavity Setups		m2k-TAL-1060-1000

¹ measured in front of rear facet

² measured in accordance to ISO 11146

³ in a non condensing atmosphere

Safety

This is a laser class IV product according to IEC - Standard International Commission (Publication 825, 1993). The laser light emitted from this laser diode is invisible and/or visible and is harmful to the human eye. The safety regulations for eye and personell protection included in the IEC Standard must be observed to avoid any harm to operating personell. Avoid direct exposure and looking into the laser diode, into the collimated beam or into the fiber when it is linked to the module.

Storage and shipping

Store and ship the diode laser with shortened electrical contacts, in a clean and dry atmosphere and in a tempertaure range of 0°C to 60°C.

Operation and handling

Diode lasers are extremely sensitive to over-voltage. Take extreme precaution to avoid electrostatic charges. Precautions against spiking during switching on and off the power supply must be assured. Correct polarity of power supply must be assured. During handling personell has to wear wrist straps. Grounded work surfaces and additional antistatic techniques are mandatory during handling.

Device failure and safety hazard are caused by operation in excess of maximum ratings. Exceeding output power and temperature specification will result in accelerated device ageing.

Do not mount via any paste-like media!



m2k-laser GmbH
Hermann Mitsch Str. 36a
D-79108 Freiburg

Fon: +49 (0) 761 5158-7370
Fax: +49 (0) 761 5158-7376

Email: info@m2k-laser.de
Internet: www.m2k-laser.de

m2k-TA-1060-1000

Example Measurement Data

The charts presented only describe typical examples. All modules are characterised individually, the results being contained in the documentation included.

The display options are subject to alteration by m2k-laser.

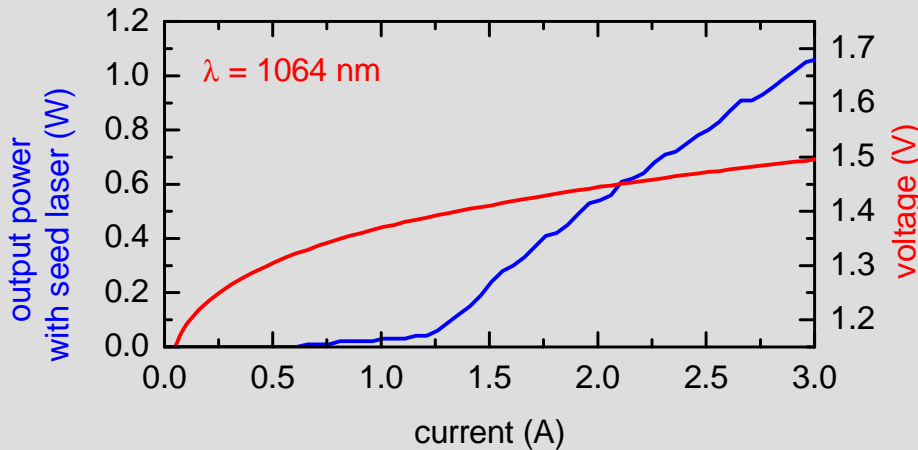

P(I) and U(I) characteristics. All measurements have been done for 20 mW seed power and at 20 °C in cw operation

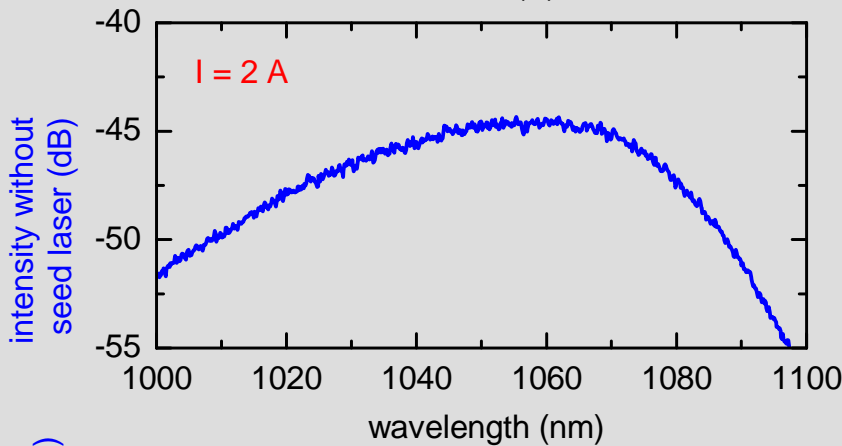

Amplifier output spectrum without seed power.

Operation beyond the central tuning range and power specified may induce increased thermal stress to the modules and thereby reduce its service life.

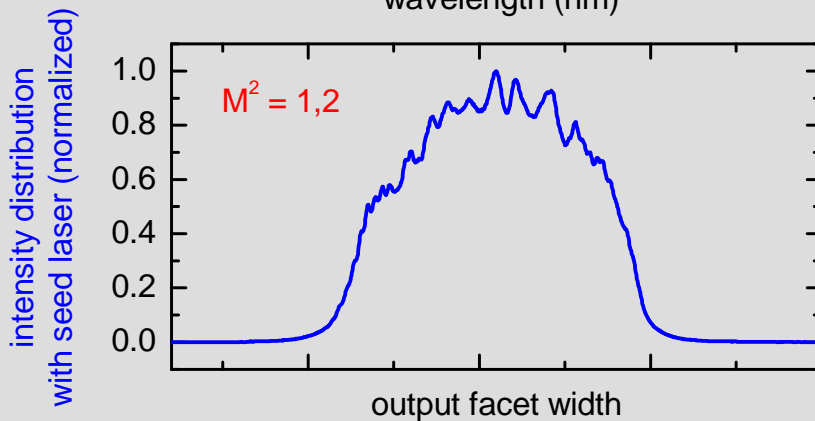

Intensity distribution at the amplifier output facet in the slow axis with seed power.

M² has been measured using a commercial BeamScope in accordance to ISO 11146.



m2k-TA-1060-1000

Package Drawings

m2k *Las*er

High-Brightness Diode-Lasers

DHP-Inset

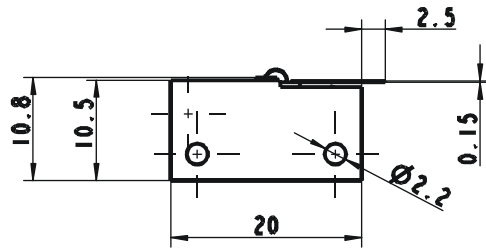

Front

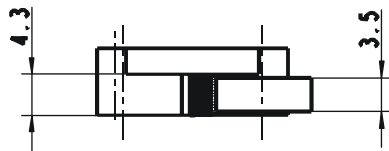

Top

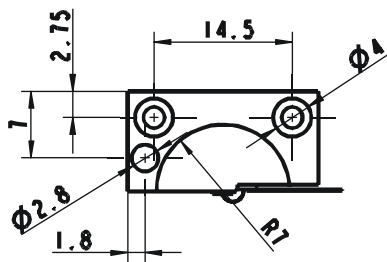

Back

C-Mount

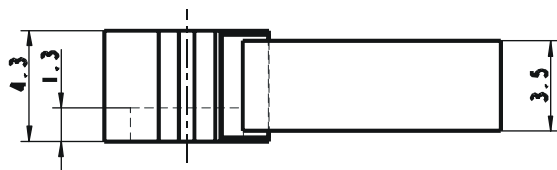
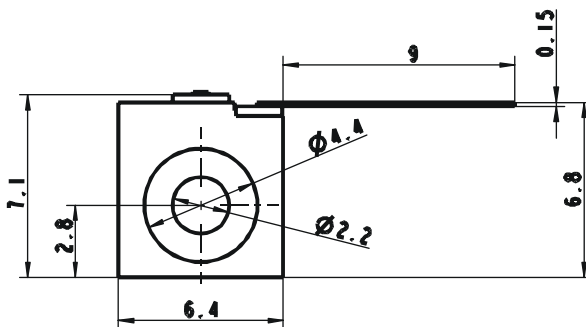

DHP-Frame

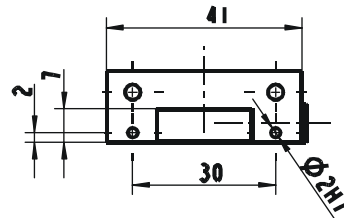

Bottom

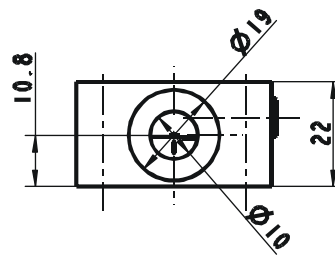

Front

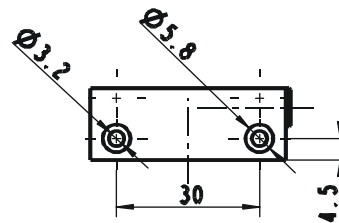

Top

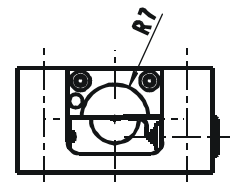

Back

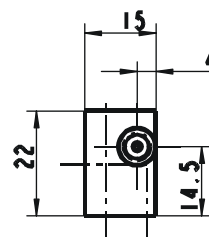

Right

